



## Drain Kit Solution

B5109 for 2.3 MW cylinder MK II

### Can be installed on

1006692 Pitch Act. 2.3 MW MRK.II wt	w/ sensor
1006693 Pitch Act. 2.3 MW MRK.II wot	w/wo sensor
B5078 Pitch actuator 2.3 MW Mrk. II	w/ sensor, w/ pins & brackets
B5079 Pitch actuator 2.3 MW Mrk. II	wo/ sensor, w/ pins & brackets

## Purpose

The overall operating conditions for a pitch cylinder is extremely demanding and requires top class design and components to ensure trouble free operation.

Seal system with low overall wear rate on rod and seals will significantly reduce the risk of leakage into hub by leading potential leakage at primary seal back to tank.

Pressure is thereby reduced from 0-200 bar to 0-3 bar on the secondary seal. Also, the contaminated oil is led back to tank, which again causes less wear on seals and rod.

## Solution

Original rod seal system, without pressure relief/drain line.      New rod seal system, with pressure relief/drain line.

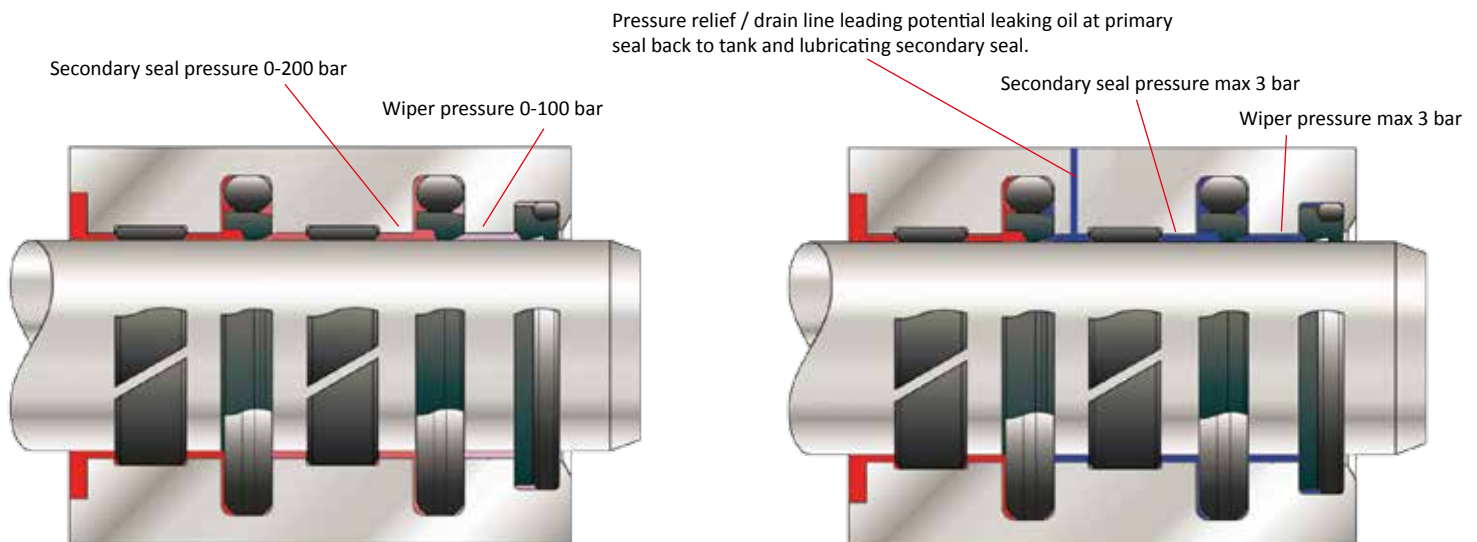

Similar solutions are mounted in numerous turbines for Siemens 3.0 MW MK I and 2.3 MW MK III & MK IV turbines worldwide.

Related documentation can be retrieved by contacting [servicehwp@hydratec-industries.com](mailto:servicehwp@hydratec-industries.com) "Introduction of drain line" and "B5109 assemble notes".

Please contact our service departments for further information. We are looking forward to supporting you.

# Hydratech Industries

Your

Regular

Maintenance

Supplier of

- *More than 30 years experience*
- *Competitive prices*
- *Technical support*
- *Spare parts & repair*
- *Online access to documentation*

- Pitch Cylinders
- Filters
- Burst Discs
- Valves
- Accumulators
- Pumps
- Motors
- **Upgrade Kits**
- Complete Hydraulic Units

Contact us 24-7

## Denmark

Suensonsvej 14  
DK-8600 Silkeborg

E-mail: [servicehwp@hydratech-industries.com](mailto:servicehwp@hydratech-industries.com)  
Tel.: +45 8722 8181

## USA

P.O. Box 2618  
22955 McAuliffe Dr.  
Robertsdale, AL 36567

E-mail: [servicehwpUS@hydratech-industries.com](mailto:servicehwpUS@hydratech-industries.com)  
Tel.: +1 251 947 5300